

MODEL 5110 DE DIAMOND DREDGE ASSEMBLED VIEW

ASSEMBLED MODEL 5110DE DIAMOND
DREDGE TOP VIEW DETAIL

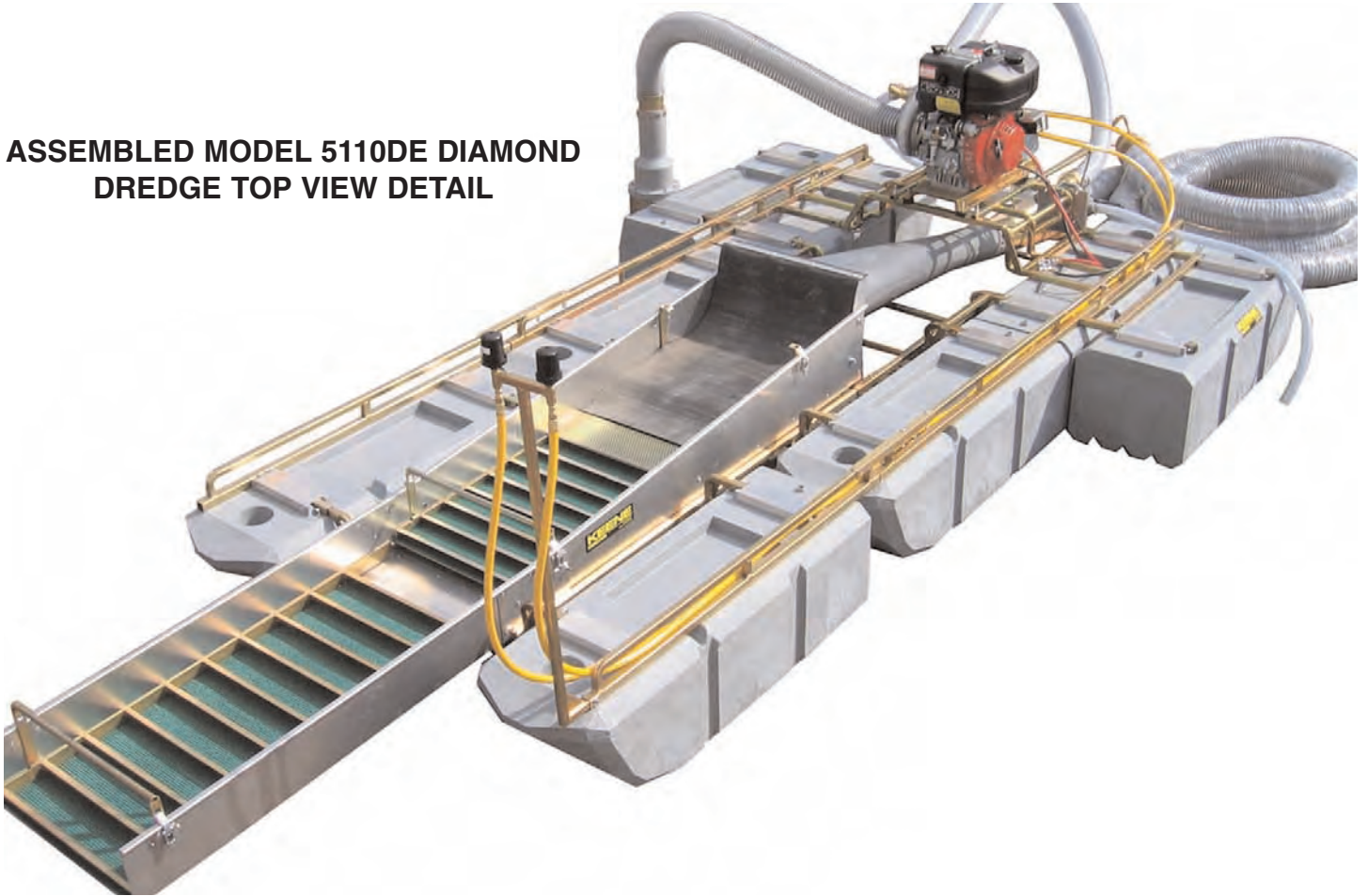

ASSEMBLED MODEL 5110DE SHOWING
ENGINE, COMPRESSOR & PRIMING
PUMP DETAIL

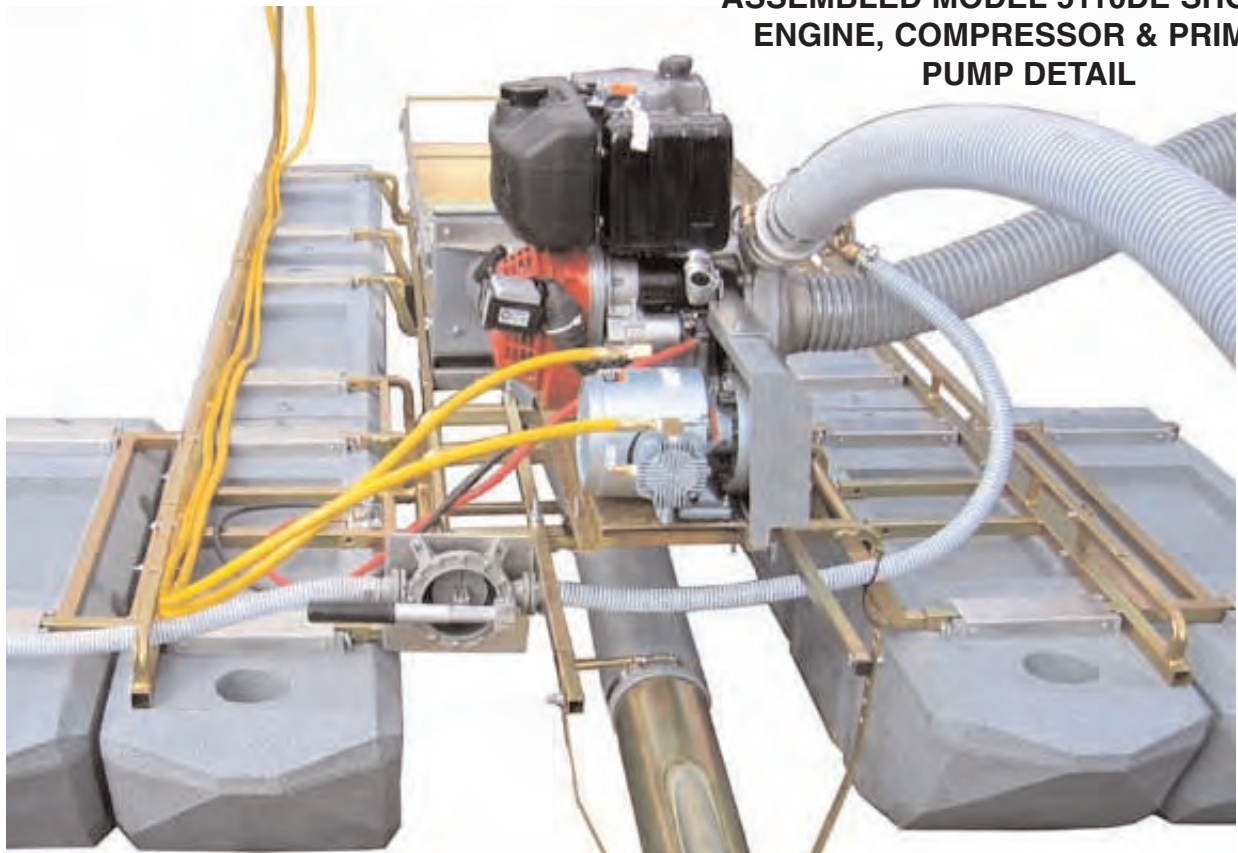

FRAME PICTORIAL MODIFICATION FOR DIAMOND DREDGE MODEL 5110DE

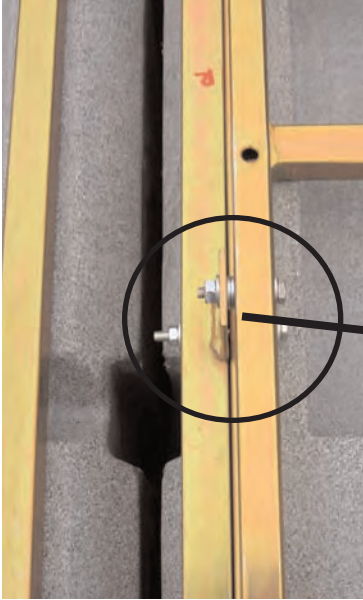

OUTRIGGER FASTEN DIAGRAM. WASHER PROVIDES SPACING OF OUTRIGGER TRIM

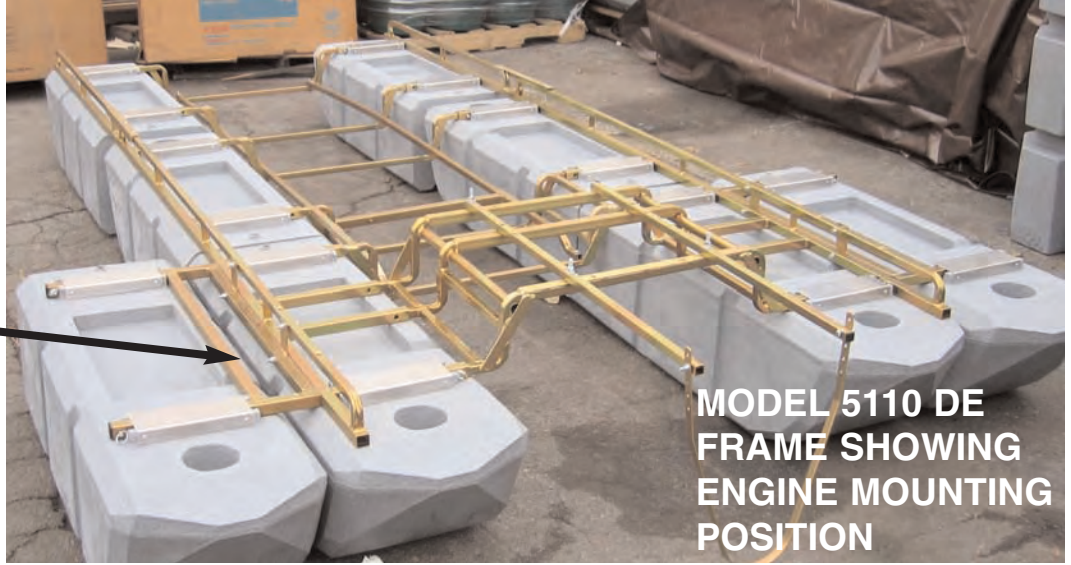

MODEL 5110 DE FRAME SHOWING ENGINE MOUNTING POSITION



MODEL 5110 DE FRAME SHOWING SLUICE MOUNT POSITION



THE ALUMINUM LIP ON THE BOTTOM OF THE SLUICE BOX SLIDES OVER PINS AND IS LOCKED IN PLACE WITH COTTER PINS

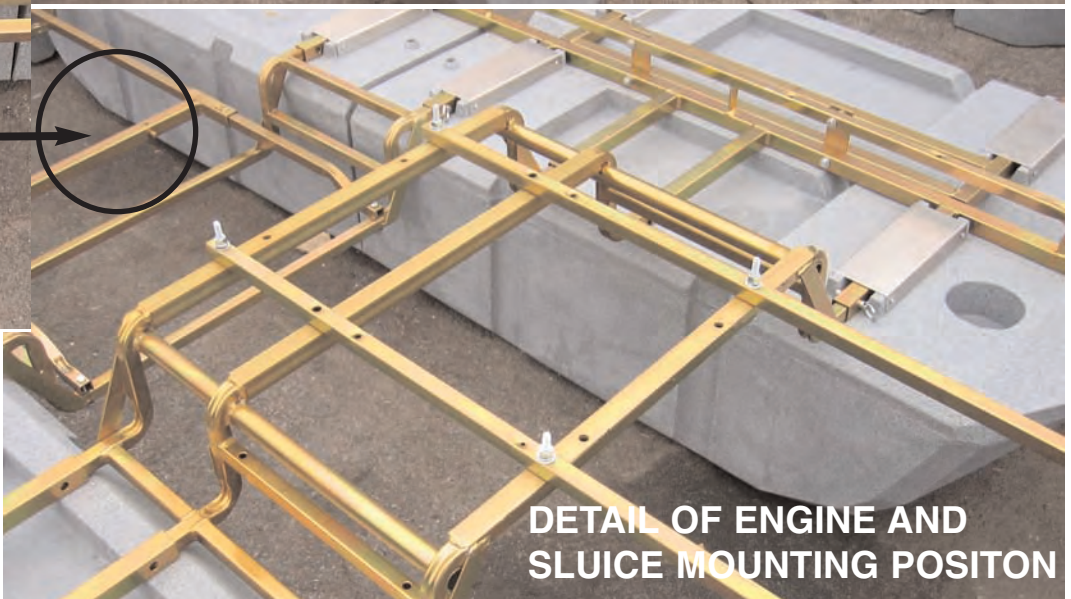

DETAIL OF ENGINE AND SLUICE MOUNTING POSITION

FRAME ASSEMBLY FOR 5100-6100 SERIES

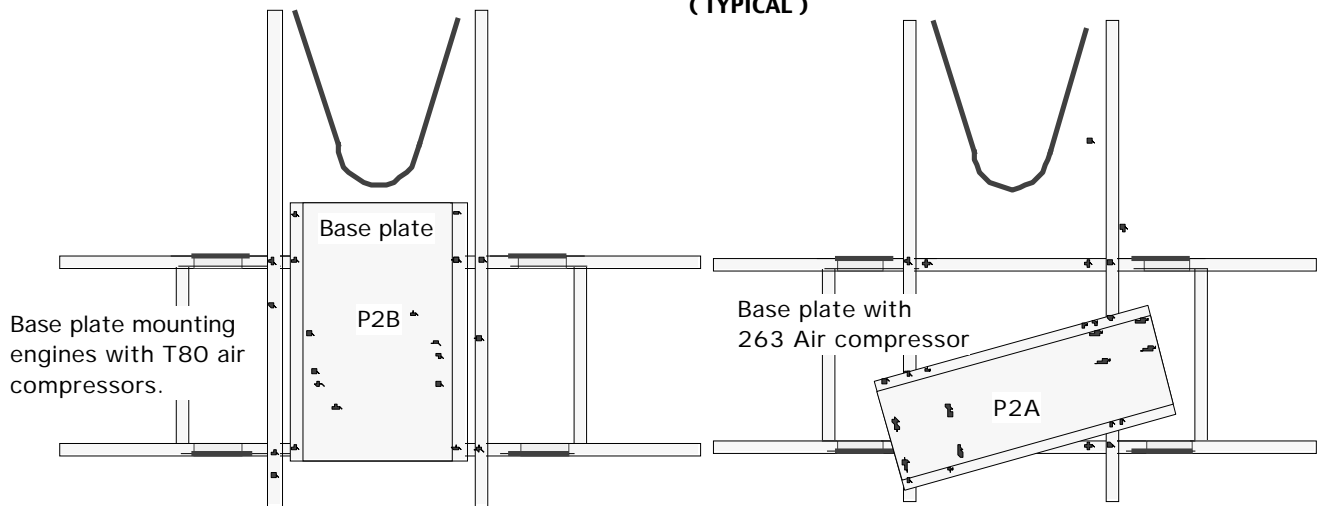
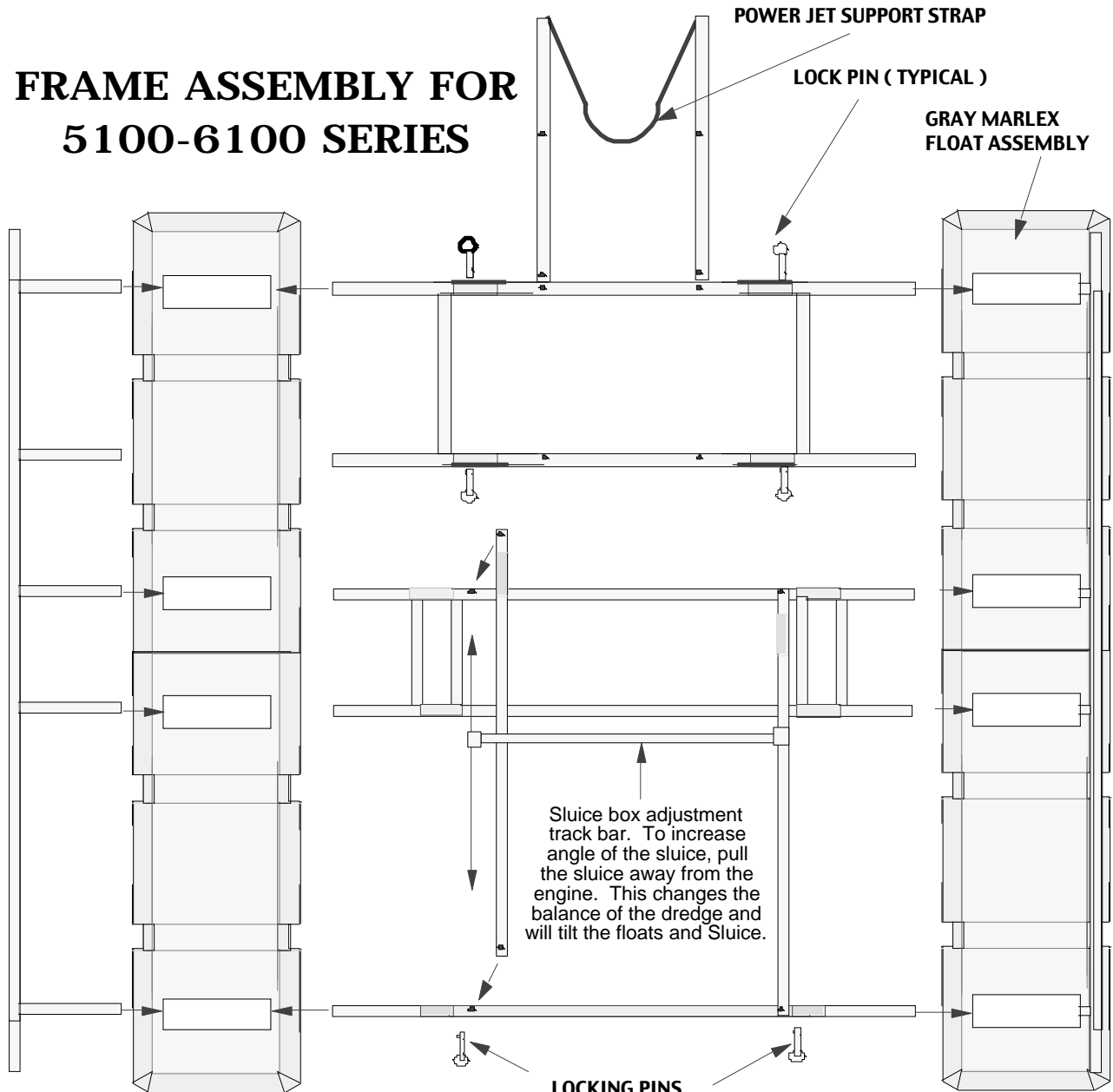

Top View 5100 & 6100 SERIES

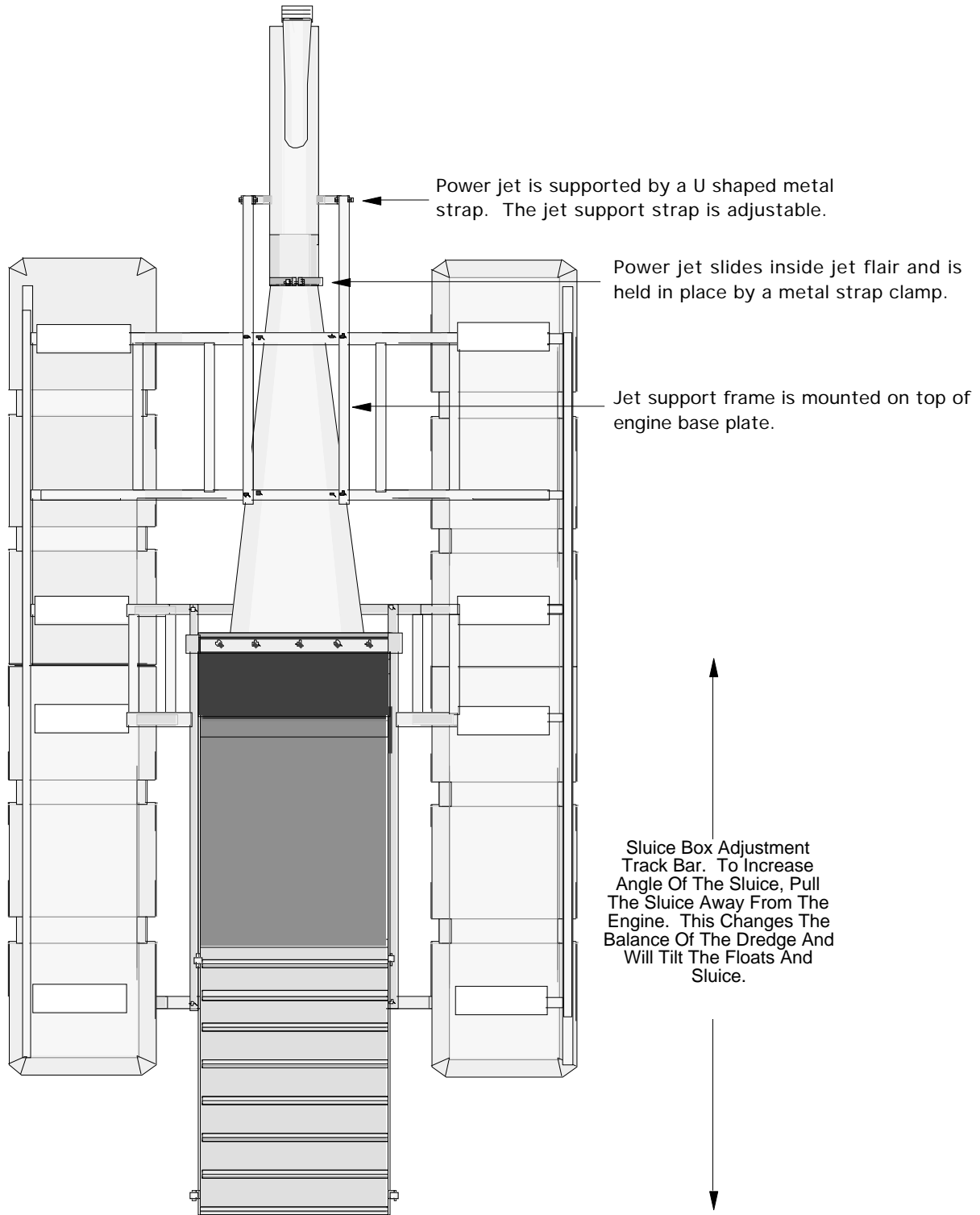

Top View 5100 & 6100 SERIES

(2) HDC3P- 3"
HEAVY DUTY CLAMPS

(1) POWER JET

VENTURI JET LOG

(1) FVA40- 4"
FOOT
VALVE ASSEMBLY

PUMP

ENIGNE

JET FLAIR

Sluice Box Adjustment
Track Bar. To Increase
Angle Of The Sluice, Pull
The Sluice Away From The
Engine. This Changes The
Balance Of The Dredge And
Will Tilt The Floats And
Sluice.

Top View
5100 & 6100 SERIES

PHC3- 3" PRESSURE HOSE

(2) HDC3P- 3" HEAVY
DUTY CLAMPS

(1) PHC3- 3" PRESSURE
HOSE COUPLING

COMPRESSOR UNIT

OPERATIONAL NOTES

TO ADJUST THE SLUICE BOX WE
RECOMMEND THAT YOU START WITH
THE SLUICE IN THE LEVEL POSITION
WHEN THE ENGINE IS A 50%,
THROTTLE. THEN BRING THE ENGINE
UP TO 70% ENGINE THROTTLE.

ADJUST SLUICE ANGLE SO THE
LIGHTER SAND WASHES AWAY, WHILE
LEAVING THE CONCENTRATES. THIS
IS DONE BY SLIDING THE SLUICE BOX
BACKWARDS AND FORWARDS WITH
THE TRACK BAR.

THE PROPER ANGLE CAN ONLY BE
DETERMINED BY EXPERIMENTATION
DO TO DIFFERENT MATERIAL
CONDITIONS.

SLUICE BOX

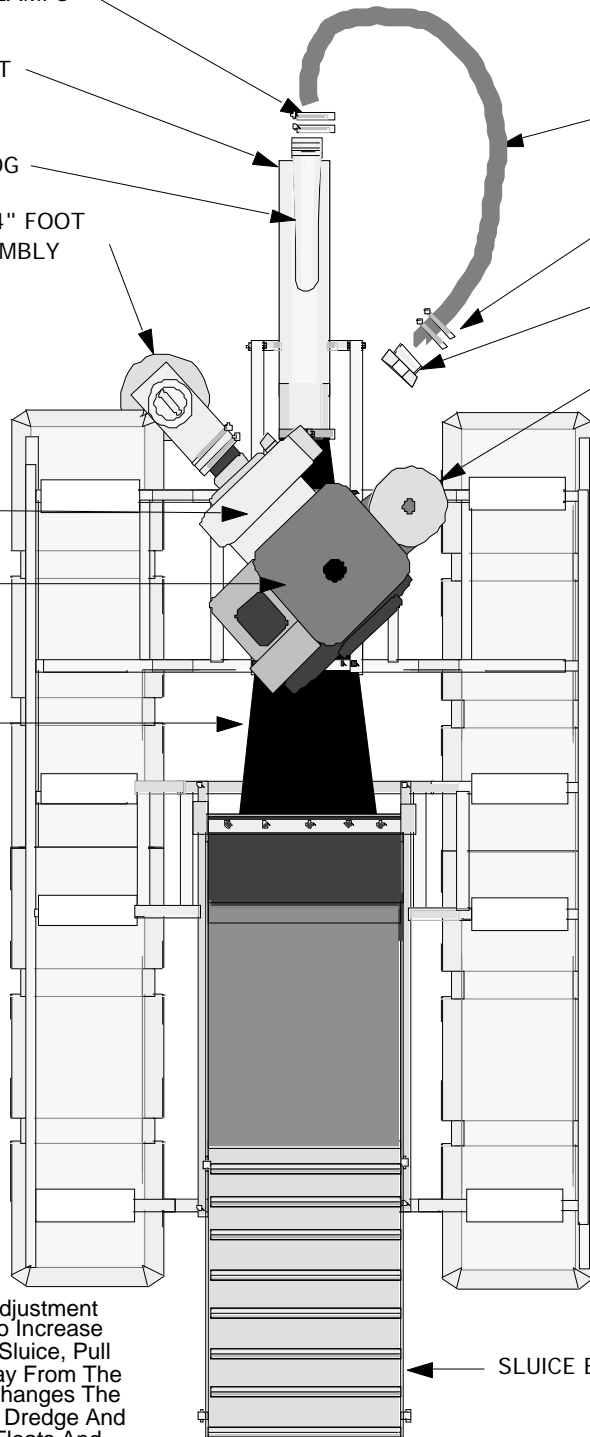

FRAME ASSEMBLY FOR 5200-6200 SERIES Twin Engine

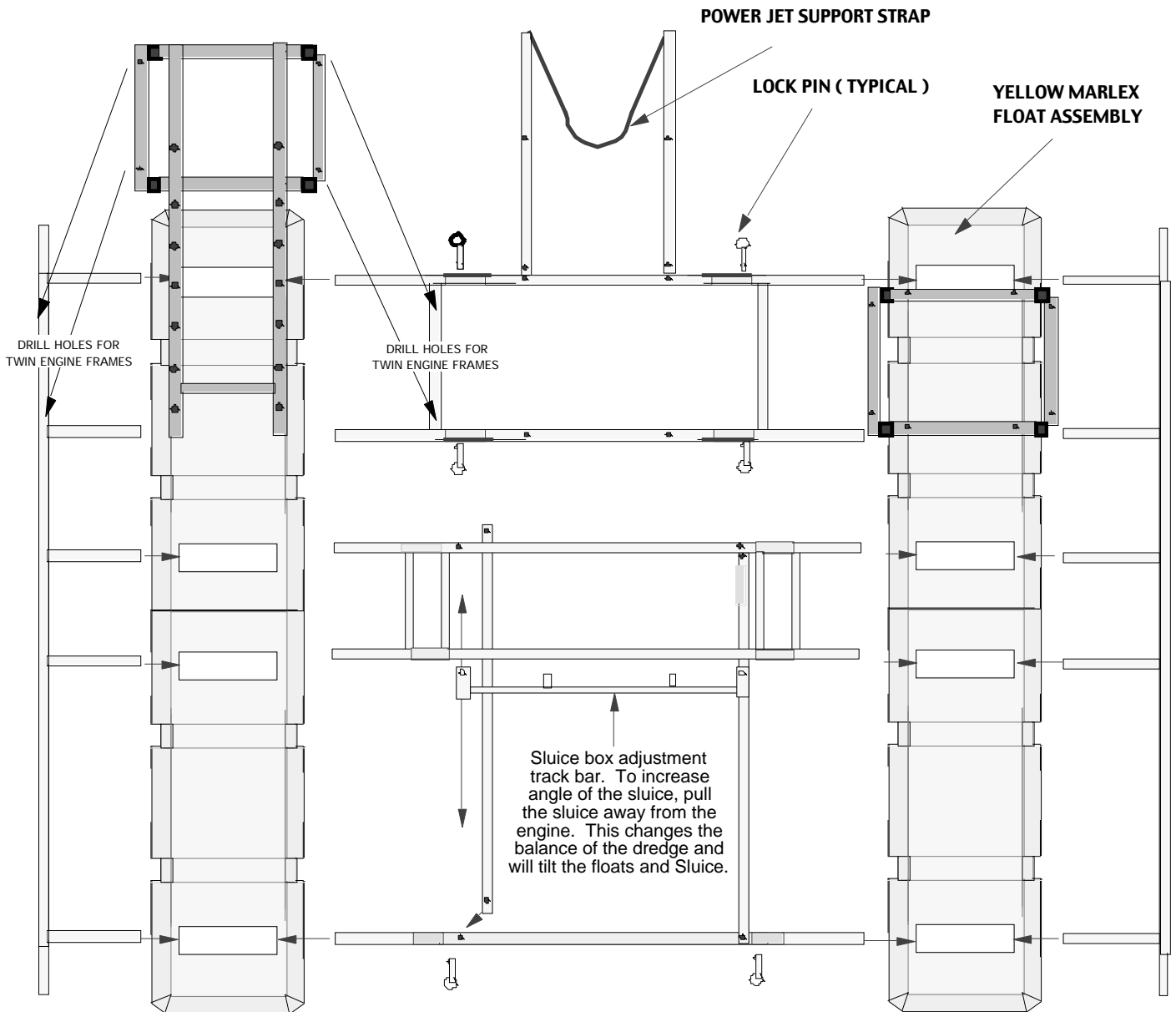

Top View
5200 & 6200 SERIES
Twin Engine

Twin engine adaptors may have to be drilled and mounted on the frame work.

Power jet is supported by a U shaped metal strap. The jet support strap is adjustable.

Power jet slides inside jet flair and is held in place by a metal strap clamp.

Jet support frame is mounted on top of engine base plate.

Sluice Box Adjustment Track Bar. To Increase Angle Of The Sluice, Pull The Sluice Away From The Engine. This Changes The Balance Of The Dredge And Will Tilt The Floats And Sluice.

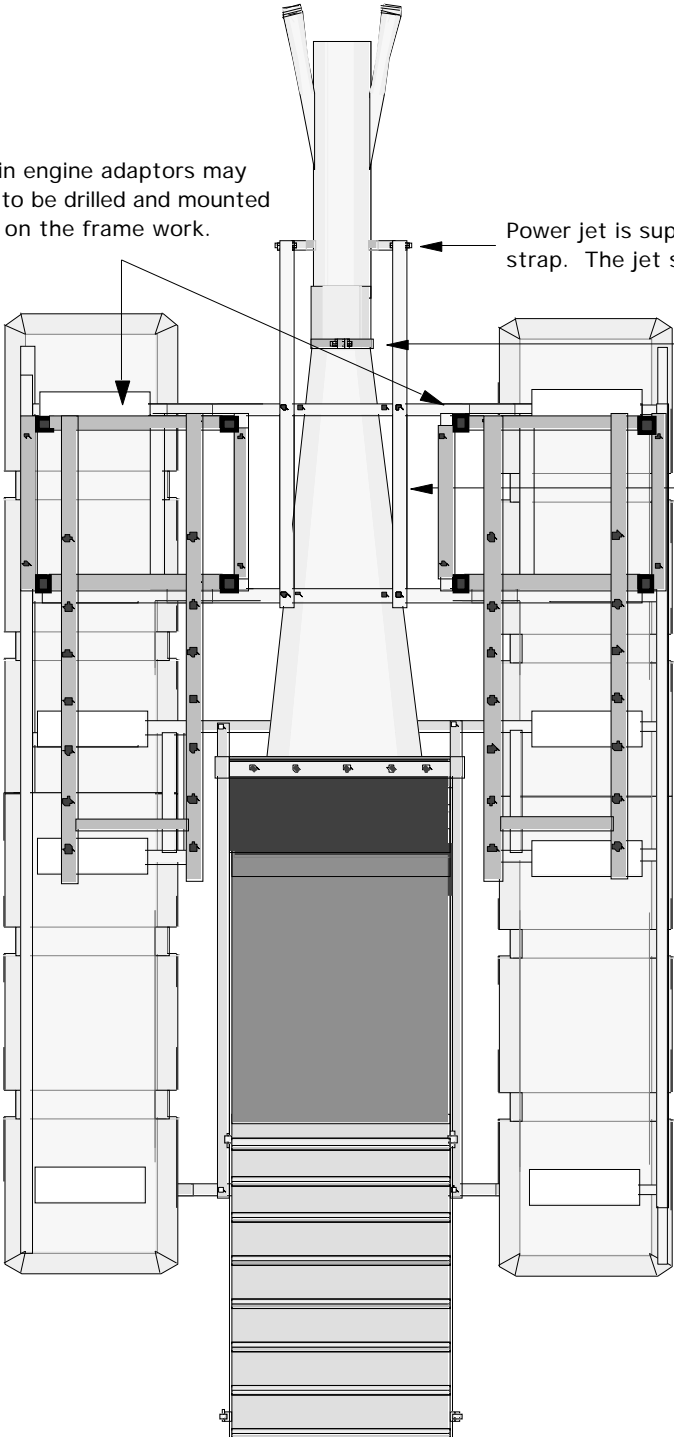

Top View 5200 & 6200 SERIES Twin Engine

(2) HDC3P- 3"
HEAVY DUTY CLAMPS

Top View
5100 & 6100 SERIES

PHC3- 3" PRESSURE HOSE

(2) HDC3P- 3" HEAVY
DUTY CLAMPS

(1) PHC3- 3" PRESSURE
HOSE COUPLING

COMPRESSOR UNIT

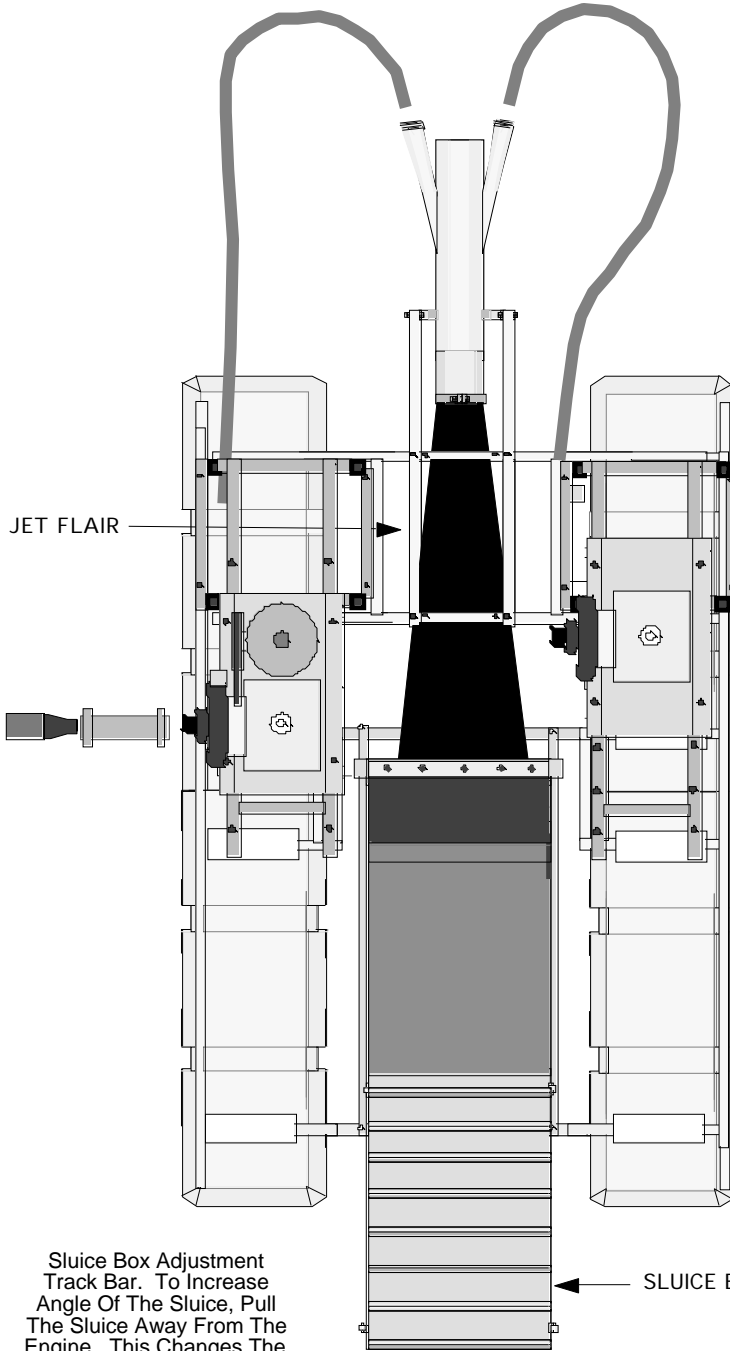

OPERATIONAL NOTES

TO ADJUST THE SLUDGE BOX WE RECOMMEND THAT YOU START WITH THE SLUDGE IN THE LEVEL POSITION WHEN THE ENGINE IS A 50% THROTTLE. THEN BRING THE ENGINE UP TO 70% ENGINE THROTTLE.

ADJUST SLUDGE ANGLE SO THE LIGHTER SAND WASHES AWAY, WHILE LEAVING THE CONCENTRATES. THIS IS DONE BY SLIDING THE SLUDGE BOX BACKWARDS AND FORWARDS WITH THE TRACK BAR.

THE PROPER ANGLE CAN ONLY BE DETERMINED BY EXPERIMENTATION DO TO DIFFERENT MATERIAL CONDITIONS.

Sludge Box Adjustment Track Bar. To Increase Angle Of The Sludge, Pull The Sludge Away From The Engine. This Changes The Balance Of The Dredge And Will Tilt The Floats And Sludge.

← SLUDGE BOX

General operating Instructions

The New Keene 3 Stage Sluice box. "Sluice technology of the future"

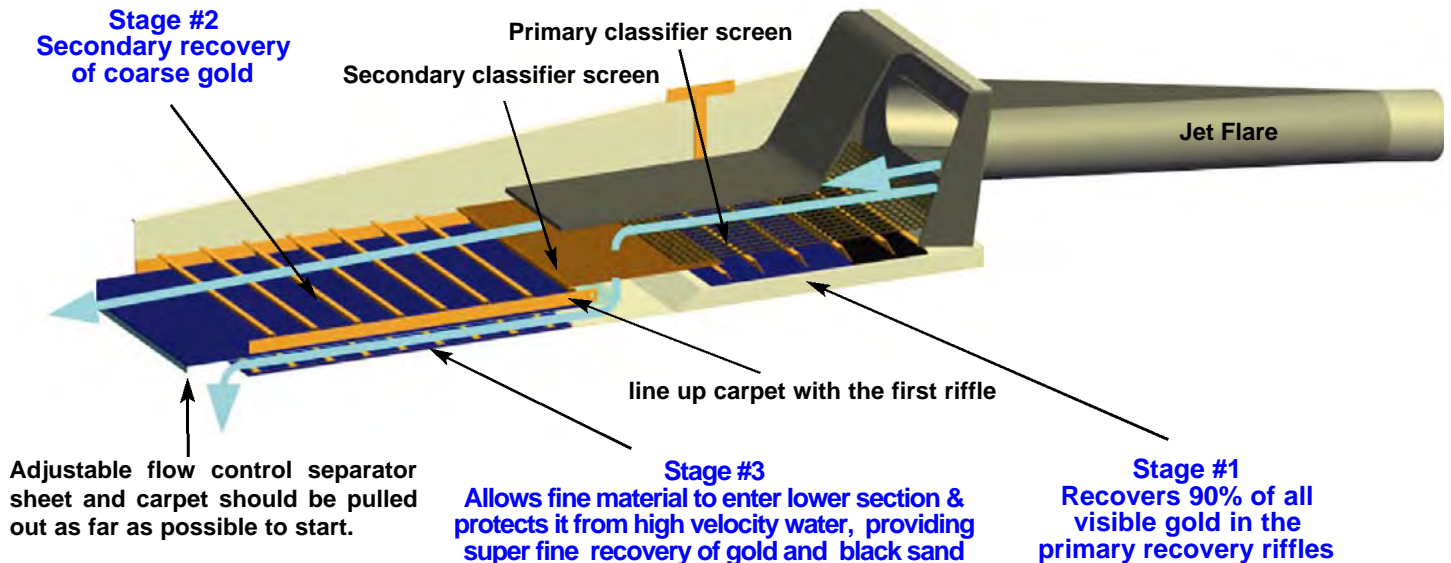

Three Stage Sluice Instructions

The 3 stage sluice box requires more water than a normal sluice box to operate correctly. We recommend that the engine be ran at least 2/3rds. throttle or higher. If the engine operates too slow the riffles may become overloaded and a loss of fine gold will occur. **The Adjustable flow control separator plate should be pulled out as far as possible to allow maximum flow into the 3rd. stage riffle area.** If the Third Stage Riffle appears to be running too clean you can move the separator plate inward decreasing the water flow allowing more material to accumulate into the riffle section.

Side view of 3 stage sluice box

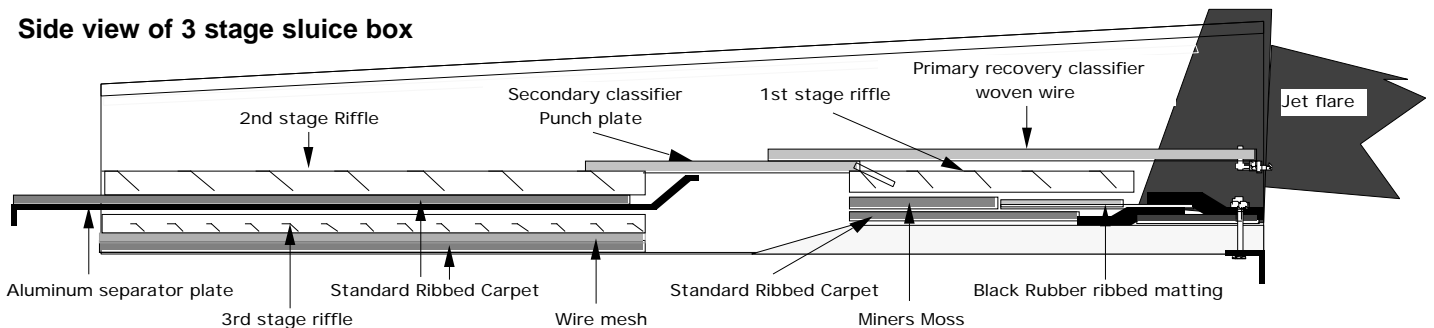

Sluice Box Tilt Adjustment

Move the sluice Box forward to increase or backward to decrease the angle. The proper sluice box angle adjustment can affect the recovery of values. If the sluice does not have enough angle the sluice box will "load up" causing the riffle openings to fill with unwanted excess material. Too much angle will cause the material to flow too fast, resulting in loss of values, evidenced by the riffles running too clean. If the sluice box is working properly, approximately one third of the riffle should be visible after pumping clean water for a minute or so. A loss of values can also occur if the ratio of solid content to water is too heavy. The solid content should not exceed 1 part material to two parts water. A normal sluice box tilt is approximately 3/4" inch to the running foot. Example: A four foot sluice box should have approximately 3 inches of tilt.

First Stage:

Cleaning the 3 Stage Sluice Box

A. Position the suction tip away from any material so it is sucking only water. Operate the engine at approximately 2/3rds. throttle speed for a several minutes to wash out any excess gravel that has accumulated in the riffle section.

B. Turn the engine off or lower the engine speed to a slow idle. Remove primary and secondary classifier screens and riffle. Remove the carpets and aluminum plate and wash the concentrates into a bucket or tub. Note: the primary riffle or 1st stage can be cleaned separately without cleaning the entire sluice box. We recommend that the primary riffle be cleaned only once or twice a day. The balance of the sluice should be cleaned every few days, depending on the type of conditions encountered.

2nd Stage:

A. Unlatch the top 2nd. stage riffle and pivot back towards the jet flare. Roll the carpet up and wash out in a bucket or tub.

3rd. Stage:

A. Lift the adjustable flow control separator sheet up on it side and rinse the concentrates in to the lower third stage sluice.

B. Remove the 3rd stage lower riffle and screen. Splash water on the riffle and screen to rinse any concentrates onto the carpet. Roll up the carpet and wash out the concentrates.

Note: many of the above clean up procedures can also be done with the engine idling, however it will require a second person to hold a tub at the end of the sluice.

GENERAL OPERATING INSTRUCTIONS

THE FOLLOWING INFORMATION SHOULD ENABLE YOU TO UNDERSTAND THE BASIC THEORY OF OPERATION OF A PORTABLE DREDGE.

For more complete understanding on this subject, we recommend you read any one of a variety of books available through the Keene Library of Books, such as The Gold Miners Handbook, Dredging for Gold or Advanced Dredging Techniques. The vacuum on a portable dredge is created by a "venturi principal". A volume of water is pumped through a tapered orifice (jet), by a special designed water pump. A high velocity jet stream is created within the jet tube producing a powerful vacuum. As indicated in the diagram gravel is dredged into the suction hose and is delivered to the sluice jet flare. As a slurry of water and gravel enters the jet flare and is spread evenly over a classifier screen. The smaller and heavier particles drop below the classifier screen into an area of less velocity, allowing a slower and more selective classification of values. Often values are recovered and easily observed before they even enter the riffle section. The lighter non bearing values and larger aggregate are returned back into the water. The riffles, or gold traps in the sluice box are best described as "Hungarian Riffles". This type of riffle has proven to be the most efficient gold recovery system. As material flows over the riffles, a vortex, or eddy current is formed between each riffle opening. This force allows the heavier material to settle out of suspension and the lighter, non value bearing material to be washed away. This continuous self cleaning principal allows a dredge to be operated for prolonged periods of time. Normal conditions require a sluice box to be cleaned only once or twice a day.

PRIMING THE PUMP

Before starting the engine, the pump must be fully primed. This means the pump must be full of water and all air removed. All jetting pumps provided with our dredges have a mechanical water pump seal. Without the presence of water in the pump, friction could cause a seal to overheat and require replacement. Priming the pump on some of the smaller models is accomplished by thrusting the foot valve back and forth under the surface of the water in a reciprocating motion. This will pump water into the foot valve assembly and into the pump. A pump is fully primed when water is observed flowing out of the discharge end of the pump. It may sometimes become necessary to hold the discharge hose above the level of the pump to complete the priming operation. The larger dredges that have a rigid foot valve, are easily primed by removing the cap provided on the foot valve and filling, until water overflows. Caution must be exercised to prevent sand from entering the foot valve or intake portion of the pump. Excess amounts of sand could damage the water pump seal, or pump impeller. It is recommended that the intake portion of the foot valve be placed in a sand free environment underwater, such as a small bucket or pan.

PRIMING THE SUCTION HOSE

Priming the suction hose need not be of concern in most dredging operations, but is important to understand the principal. When the tip of the suction hose is taken out of the water during operation air will enter the suction system and cause the suction power to cease temporarily, until submerged again. The suction will commence as soon as the air has passed through the system. It is important to ensure that no air leaks occur in the suction system.

SUCTION SYSTEM OBSTRUCTIONS

The suction system can become jammed while dredging. This can be caused by dredging an excess of sand, causing the suction hose to load up, or a rock that has become stuck in the suction system. Rock jams generally occur in the jet, or just before entry into the jet. This can easily be cleared by removed by flipping the rubber damper back over the jet flare and thrusting the probe rod down through the jet flare and jet in an effort to strike the obstructed area. It may occasionally be necessary to remove the suction hose to remove an obstruction. If this is not successful, it may be necessary to locate the blockage in the transparent hose and dislodge it by a striking the obstruction, taking care not to damage the hose.

SOLID CONTENT

Care must be exercised to prevent dredging excess amounts of sand. A solid to water balance must be maintained. The solid content being dredged should never exceed 10%. If a suction tip is buried in the sand and not metered properly the solid content could cause the suction hose to become overloaded with solids and suction will cease, this will also cause the sluice box to become overloaded with solid content, resulting in a loss of values.

SLUICE BOX ADJUSTMENT

Most models have a slight adjustment to raise or lower the sluice box. The proper sluice box adjustment can effect the recovery of values. If the sluice does not have enough angle, the sluice box will "load up" causing the riffle openings to fill with unwanted excess material. Too much angle will cause the material to flow too fast, resulting in loss of values, evidenced by the riffles running too clean. The optimum adjustment of a properly working sluice box is evident by only a portion of the riffle is visible while operating. A loss of values can also occur if the solid content of the suction discharge is too heavy in solid content. Remember, the solid content should not exceed 10 %. A normal sluice box tilt is approximately 3/4" inch to the running foot. A four foot sluice box should have an approximate tilt of 3"

CLEANING THE SLUICE BOX

Before attempting to clean the sluice box, it should be allowed to run with only water for a few minutes in order to wash

out any excess gravels that have accumulated. Either turn engine off, or let run with a slow idle, then remove the classifier screen and replace the wing nut to prevent losing it. Unsnap the riffle latches, fold the riffle tray up, and let rest against the jet flare, taking care not to let it drop back into place while cleaning. This could result in a potential injury! Place a wide tray, bucket or large gold pan at the end of the sluice, then carefully roll up the riffle matting and wash into the container at the end of the sluice. Rinse any excess gravel that remains in the sluice into container. All material must be removed before replacing the riffle matting, riffle tray and classifier screen.

ENGINE SPEED

Most small engines are throttle controlled. The speed of the engine can be controlled with the use of a lever. Although the rated horsepower is achieved on most small engines at 3600 R.P.M., it may not be necessary to operate the dredge at full speed. Lower speeds conserve engine life and fuel economy. Be sure to read all instructions and especially the engine instructions that are provided with each unit. **ENGINES ARE NOT SHIPPED FROM THE FACTORY CONTAINING OIL. OIL MUST ADDED PRIOR TO USE! ENGINES OPERATED WITHOUT SUFFICIENT OIL SUPPLY WILL INVALIDATE ENGINE WARRANTEE!**

TROUBLE SHOOTING

[A] IF SUCTION DECLINES

1. Check the suction device for an obstruction. An obstruction can be removed by probing the obstructed area with the provided probe rod. It may be necessary to check the suction hose for a visible obstruction. This can be remedied by either back flushing the system or dislodging the obstruction with a gentle blow.
2. Check the pump for loss of prime or blockage. The foot valve may be too close to the surface of the water and air may enter the intake of the pump via a small whirlpool. The pump intake or foot valve screen may be plugged with leaves or moss, restricting flow into the intake of the pump. Check and tighten all clamps to prevent an air leak.

[B] IF PRIMING THE PUMP BECOMES DIFFICULT

1. Check all clamps for an air leak.
2. It may be necessary to check the foot valve for a small leak. This is accomplished by removing the foot valve assembly from the pump and blowing air into the hose portion of the assembly and listening for an air escape. It may be necessary to remove the hose and check the rubber valve for an evidence of a leak, or for a small obstruction preventing the valve from sealing.
3. If a water pump seal is either defective or damaged, a leak will be evident on the inside portion of the pump around the drive shaft. Often a new pump will leak slightly, until the seal and gasket has become fully seated. This is a common occurrence in most new pumps.

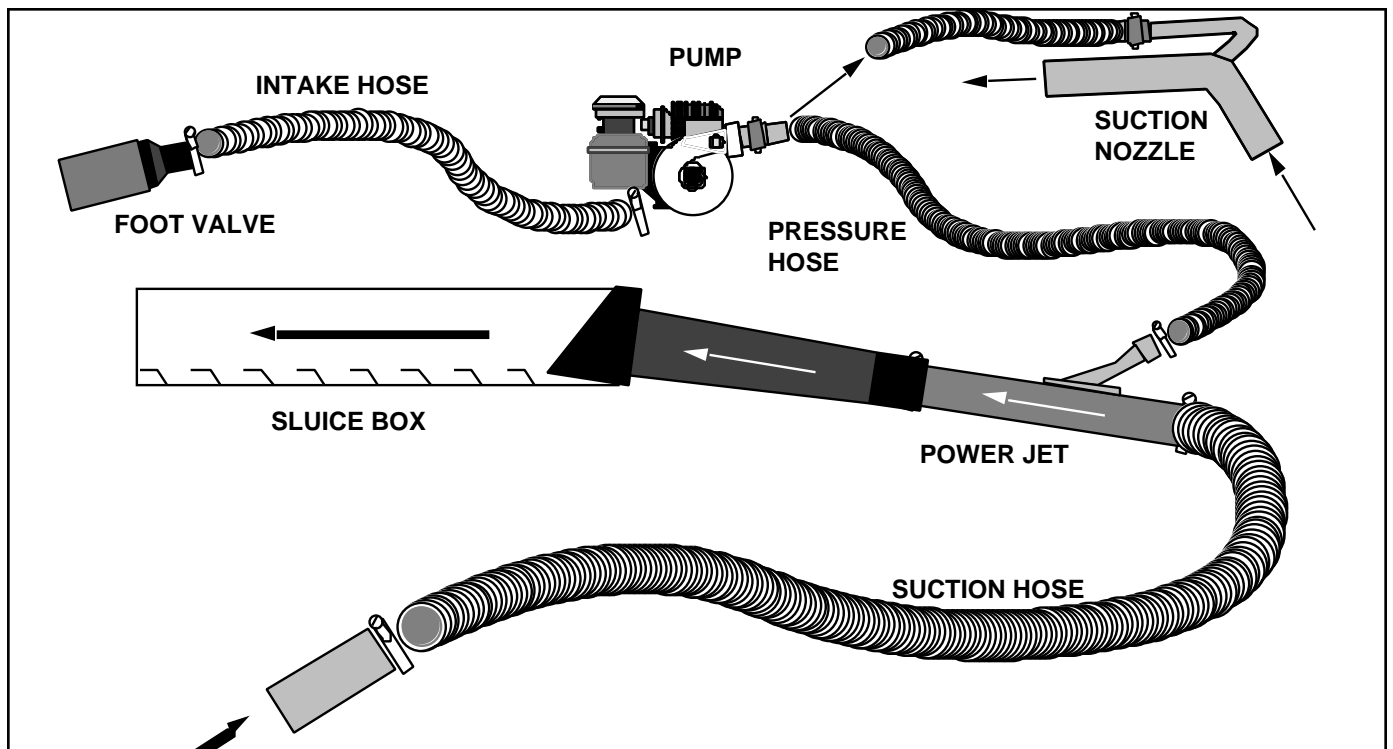

CENTRIFUGAL PUMP ASSEMBLY

STANDARD 5/8" TREADED SHAFT ENGINE

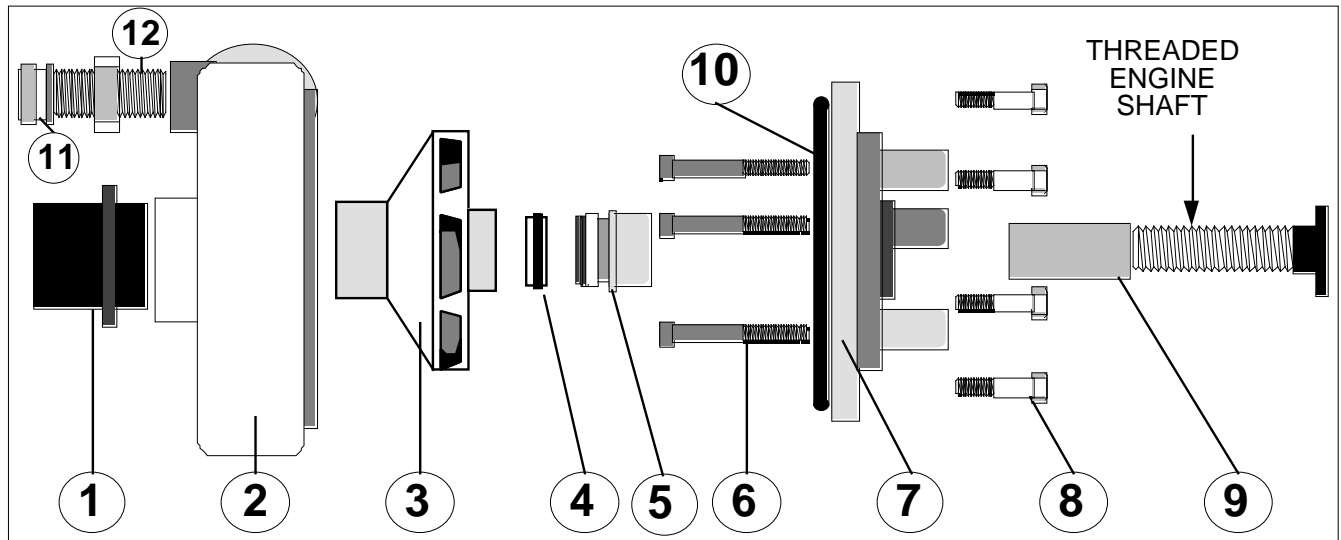

P100 and P180 PUMPS

ITEM	DESCRIPTION	QUANTITY	P100	P180
			PART NO.	PART NO.
1	HOSE ADAPTER	1	HA1	HA1
2	OUTER HOUSING	1	101	181
3	IMPELLAR	1	102	182
4	PUMP SEAL (CERAMIC SEAL)	1	WPS2(P.T.1)	WPS2(P.T.1)
5	PUMP SEAL (SPRING & CASING)	1	WPS2(P.T.2)	WPS2(P.T.2)
6	MOUNTING PLATE BOLT	3	MB	MB
7	MOUNTING(BACK) PLATE	1	105	105
8	HOUSING BOLT	4	HB	HB
8A	HOUSING BOLT WASHERS	4	HW	HW
9	SHAFT BUSHING	1	SB	SB
9A	COMPRESSOR DRIVE	1	P3	P3
10	"O" RING(GASKET)	1	104	104
11	FLUSHER ADAPTER CAP	1	FAC	FAC
12	FLUSHER ADAPTER	1	FA	FA
13	FAC RUBBER SEAL(INSIDE CAP)	1	FACS	FACS

INSTALLATION NOTES:

The rotation of all is counter-clockwise. Water must be contained within the pump while it is running. Do not run the pump dry, as it will damage the pump seal and may lead to the need to replace the seal. To ensure continuous performance, it is always a good idea to carry a spare seal, in case you need to replace it. For maximum pump performance, use only Keene Engineering foot valves.

INSTALLATION INSTRUCTIONS:

- Before installing the mounting plate (7) to the engine, the spring portion of the water pump seal (5) must be installed. Place this portion of the seal into the center of the mounting plate, with the use of a light hammer and or blunt instrument and a seal setting tool. Tap the perimeter metal portion of the seal to set the seal into position. Care must be taken to avoid contact with the carbon portion of the seal. A small amount of Silicone Rubber Cement placed in this section will insure a water tight seal. Insert the FOUR mounting bolts (6) into the mounting plate (7). Tighten the bolts evenly so as to prevent mis-alignment.
- Fit "O" Ring gasket (OR1) into "O" slot on the front face of the mounting plate, making sure that it is properly seated. Place the ceramic portion of the water pump seal (4) into the center of the impeller (3) firmly, using the heel of your hand to insure a proper fit. The ceramic surface of the seal must be facing outwards. Thread the impeller onto the engine shaft by turning it gently in a clockwise rotation, taking care to avoid damage to the threads on the impeller.
- Attach the outer housing (2) to the mounting plate, using the housing bolts (8) and washers (8A). Tighten the housing bolts evenly to ensure proper tension and alignment. Extreme care must be taken to prevent over tightening of the bolts. Too much torque will damage the threads in the outer housing.

CENTRIFUGAL PUMP ASSEMBLY P280, P350 and P350S PUMPS

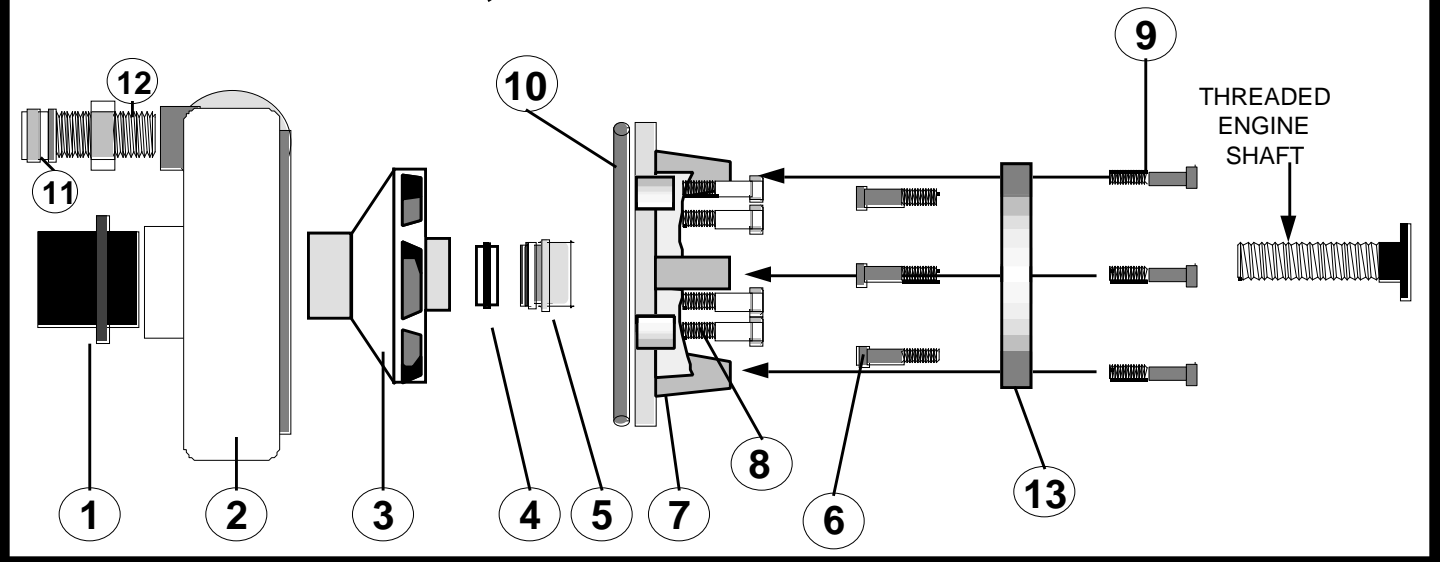

ITEM	DESCRIPTION	QUANTITY	P280 PART NO.	P350 PART NO.	P350S PART NO.
1	HOSE ADAPTER	1	HA25	N/A	N/A
2	OUTER HOUSING	1	201	301	301S
3	IMPELLAR	1	202	352	352S
4	PUMP SEAL (CERAMIC SEAL)	1	WPS3 (PT.1)	WPS3 (PT.1)	WPS3 (PT.1)
5	PUMP SEAL (SPRING & CASING)	1	WPS3 (PT.2)	WPS3 (PT.2)	WPS3 (PT.2)
6	ENGINE MOUNTING BOLTS	3	EB	EB	EB
7	3 LEG MOUNTING BRACKET	1	207	207	207
8	HOUSING BOLT	4	HB	HB	HB
8A	HOUSING BOLT WASHERS	4	HW	HW	HW
9	3 LEG MTG. BRACKET BOLTS	3	AB	AB	AB
10	GASKET	1	208	208	208
11	FLUSHER ADAPTER CAP	1	FAC	FAC	FAC
12	FLUSHER ADAPTER	1	FA	FA	FA
12A	FAC RUBBER SEAL (INSIDE CAP)	1	FACS	FACS	FACS
13	ENGINE MOUNTING BRACKET	1	204	204	204
14	COMPRESSOR GUARD SHIELD	1	CGS	CGS	CGS

INSTALLATION INSTRUCTIONS:

1. Before installing engine mounting bracket (13) to the engine, the 3 leg bracket pump bracket (7) or engine adapter rings must be bolted to the engine mounting bracket and the engine mount bolts (6) must be fitted into place as illustrated. The spring loaded portion of the water pump seal (5) must then be installed in the 3 leg adapter. Place this portion of the seal into the center as shown, with the use of a seating tool (WPK3) and a light hammer. Care must be taken to avoid contact with the carbon portion of the seal. A small amount of silicone sealant is placed in this section to ensure that a water tight seal is accomplished. Insert the three mounting bracket bolts (6) into the engine mounting plate (13) to attach the 3 leg adapter as illustrated. Align the 3 leg pump bracket (7) in the proper position to the engine mount bracket. Tighten evenly, to prevent mis-alignment. If you are installing the compressor mount bracket, be sure to place engine pulley, with drive belt attached, onto the engine shaft, before mounting this assembly to the engine. Make sure to tighten the set screw on the pulley. Be sure to install BELT SHROUD before use. IF NOT AVAILABLE CONSULT WITH FACTORY.

2. Place the ceramic portion of the water pump seal (4) firmly into the center of the impeller, using the heel of your hand to insure a proper fit. Lubricate the outer portion of the seal to assist in proper placement of this portion of the seal. The smooth ceramic surface of the seal must be facing outwards. Thread the impeller onto the shaft in a clockwise fashion, by turning gently, taking care to avoid damaging the threads on the impeller.

3. Fit the pump gasket (10) onto the 3 leg mount bracket (7) and align holes before attaching the pump housing. Attach pump housing (2) to the mounting plate, using the housing bolts and washers (8 & 8A). Tighten housing bolts evenly, to ensure proper tension and alignment. Just snug the bolts up. The paper gasket may leak for the first 5 minutes until the gasket begins to swell, as it fills with water. Extreme care must be taken to prevent over tightening of the bolts. Too much torque will damage threads in the pump housing.

ALWAYS REMEMBER THAT RUNNING YOUR PUMP DRY WILL LEAD TO POSSIBLE DAMAGE AND DESTRUCTION OF THE WATER PUMP SEALS. IT IS RECOMMENDED TO KEEP ON HAND, ONE WATER PUMP SEAL KIT AND ONE ADDITIONAL WATER PUMP SEAL WHEN WORKING IN AN ISOLATED AREA.

KEENE ENGINEERING
20201 Bahama Street Chatsworth California 91311
Tel. (818)-993-0411 Fax. (818)-993-0447
E-mail: keene@jetlink.net
Web site www.keeneengineering.com

**INSTALLATION & REPLACEMENT OF A PUMP SEAL, MARLEX PUMP
COUPLER & A COMPRESSOR DRIVE ASSEMBLY**

The water pump seal must be replaced if water is observed leaking between the engine and pump adapter or around the engine shaft,. To replace a seal or to install a compressor drive assembly (engine shaft pulley and drive belt), the pump must first be removed from the engine.

INSTRUCTIONS TO REMOVE THE PUMP FROM THE ENGINE:

Note: If the pump has been in use for a year or more, we suggest that you apply a penetrant such as "WD-40" to the engine shaft threads and allow it to penetrate the threads of the engine shaft. Saturate for 24 hours before attempting to remove the impeller from the engine shaft!

1. Remove the four housing bolts and remove the pump housing. If the housing does not pull off easily, gently pry it off with a screwdriver. Inspect the housing gasket and replace if necessary.
2. The impeller is directly mounted to the engine shaft and will unscrew in a counter clockwise direction. Before attempting to remove the impeller the engine shaft must be locked in a fixed position to prevent it from turning. A simple way of locking the shaft is to insert a pointed tool such as a screwdriver or an awl through one of the many holes in the starter assembly and turning the engine over until the tool is firmly locked in place by the starter housing cover.

IMPORTANT: Always disconnect the spark plug wire before attempting any repairs or service on your pump or engine. Once the engine shaft is locked into position, there are two methods that can be used to remove the impeller.

Method #1. Use a block of wood, such as a 2x4 and place one corner of it into one of the impeller vanes on the left side of the impeller and strike the block of wood sharply with a hammer. This should loosen the impeller and enable it to be unscrewed in a counter clock-wise direction.

Method #2. If the above is not successful, use a thin breaker bar or a heavy duty screw driver. Insert the blade into one of the impeller vanes towards the left side and try to unscrew the impeller by applying a downward pressure. If this still does not work carefully strike the end of the bar with a hammer until the impeller loosens from the shaft. If this still does not work, strike gently with a hammer. This method may cause a chip in the vane of the impeller. Depending on the size break of the corner of the impeller, it may or may not have adverse effects on the performance of the pump. So be careful!

SEAL REMOVAL AND INSTALLATION:

1. All of our pumps use a two piece seal assembly, with the exception of some older models (P-50 and P-60). One half of the seal located in the backside of the impeller is called the "seat", or ceramic portion. The other side of the seal is shrouded in a brass encasement, encasing a hardened material that rests against the ceramic portion of the seal. Always replace both sides of the seal. Remove the ceramic portion with a sharp object similar to a screwdriver and press the new seat into place by hand. Always inspect the seal to note that it is not cracked. Always place the smooth surface of the seal to the outside.

2. Remove the pump adapter from the engine and press the brass portion of the seal towards the outside from the back of the adapter. If it cannot be pressed out easily, place a screwdriver handle on the seal and gently tap it out. When replacing, it is suggested that a small amount of silicone sealant be placed on the brass portion that fits into the adapter to ensure that it will not leak. Be careful not to get any sealant on the face of the seal. Position the seal in the center of the hole and press gently by hand into the cavity as far as possible. Use a screwdriver or a blunt instrument and tap the seal gently around the edge of the seal in a circular motion until the seal is firmly fitted into place. Wipe off seal facing with a clean cloth before reassembling.

3. After both sides of the seals is installed, replace the pump adapter onto the engine and carefully tighten. Thread the impeller onto the engine shaft until the impeller is hand tight. Install the housing and use care not to over tighten the bolts to avoid stripping the threads as they are a soft alloy aluminum.

HOW TO INSTALL THE HOSE ADAPTOR PUMP INTAKE COUPLER: (For all models except the P-50 and P-300 Series).

The tolerance of the Hose Adapter is critical for proper pump performance. The hose Adapter should be installed as close as possible to the intake portion of the impeller. Center the adapter into the housing opening and press in by hand to locate it into place and place a wooden block against the outside of the adapter and gently tap until the adapter is firmly seated against the face of the impeller. Pull the starter rope until the engine turns. When the coupler is properly seated, the engine should be somewhat difficult to turn over, making sure that the adapter is against the face of the impeller.

COMPRESSOR DRIVE INSTALLATION:

To install the shaft pulley and belt for a compressor adaptation, the pump must be completely removed from the engine. For larger engines to include the 8 HP through 18 HP engines, slide the pulley to the back of the engine shaft and tighten the set screw. To install the engine pulley on smaller engines to include the 3HP to 5HP Engines, the furnished bushing should be pressed onto the pulley at the factory to ensure proper alignment and spacing. If you choose to install it yourself, this can be accomplished by placing the pulley on a flat surface, center the bushing in the hole of the pulley and gently drive it through by tapping it with a hammer taking care not to damage the bushing. The bushing should be pressed or driven through the pulley, in a flush position to the other side of the pulley. It should not extend though the other side. Then install the V Belt before placing the pulley and bushing over the engine shaft. After the pump is installed and secured, mount the compressor and compressor pulley. Install the V Belt to compressor and make sure that the alignment is correct. You can compensate for some misalignment by adjusting the compressor pulley on the compressor shaft. Tighten firmly the set screw and all bolt and check for any misalignment before starting.

Introduction to Hookah Diving

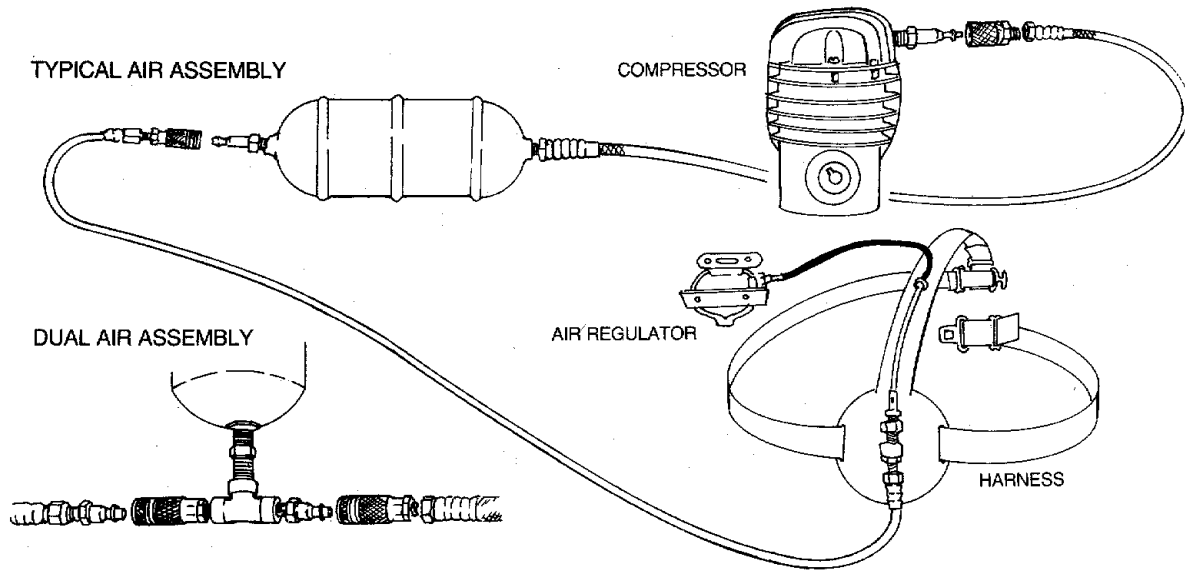

There are two air supply systems that are used for underwater diving activities. One system, known as Self Contained Underwater Breathing Apparatus (SCUBA), involves the use of high pressure metal tanks which are worn on the diver's back while diving. The equipment used in SCUBA diving is quite technical in nature, and SCUBA gear should not be used by persons who have not become a certified diver involving specialized instruction. Without a certification card indicating completion of such a course, you cannot purchase compressed air.

Of course, the SCUBA air system has its advantages as well. A diver using SCUBA gear is literally "an entity unto himself," since he carries his life giving air supply on his back at all times. He can go anywhere he chooses, completely free of any ties with the world topside.

There are many times when an underwater diver does not need the total freedom that is afforded by the SCUBA air system, particularly in cases in which the diver is sub-

merged in a limited area for long periods of time.

For these applications, the "Hookah" (Surface Air Supply) was invented. The Hookah air system uses no high pressure air tanks of the type worn on a diver's back. Instead, it uses a small air compressor which is located at the surface. It is commonly powered by a portable gasoline engine or electric motor, and the air is delivered to the diver via a floating air hose. With the Hookah system, the diver has an unlimited and nearly "cost free" air supply which will only stop flowing when the engine or motor that powers the compressor ceases to operate. This makes for a truly economical air system, which will quickly pay for itself when compared to the cost of refilling a SCUBA tanks every hour or so.

The only operating cost for a Hookah system is fuel, since the vast majority of Hookah compressor units are gasoline powered. It is not uncommon to get two hours diving time on a single gallon of gas, which shows just how economical the

Hookah air system can be.

Most Hookah divers will have a partner working "topside" as a safety man, and he can refill the engine's gas tank as it starts getting low. This will enable the diver to stay submerged so long as he desires.

THE AIR COMPRESSOR



Typical Hookah Air Compressor
Model T-80

The Hookah air system begins at the diver's air compressor. Hookah compressors are small, lightweight, and of simple design. They are commonly constructed of an aluminum alloy, and utilize a rubber diaphragm as the means of air displacement. There are also compressors that use a "piston" arrangement to displace air and these types generally deliver more air at higher pressures than the diaphragm models. The moving parts inside a Hookah compressor are lubricated with Teflon for the life of the unit, and need no additional lubrication; to do so may actually damage the compressor. The air that is delivered by this type of Hookah compressor is pure, oil free air. It is however recommended that at least a 40 micron filter be included to remove any solid particles that may occur. This type of Hookah compressors contains sealed bearings rather than oil for lubrication which can contaminate the air supply. Most compressors utilize an "oil bath lubrication system which will contaminate the air supply.

Hookah compressors operate at a relatively low pressure. The maximum pressure available from the higher capacity models is about 125 pounds per square inch. The higher the operating pressure, the lower the air output. Consistently high operating pressures (unless the unit specifically designed for high pressure use) will shorten the life of the compressor by a noticeable degree. Conversely, the LOWER the operating pressure, the greater the air output, and the longer the compressor life. A compressor should not be operated at high pressures unless a diver intends to be submerged at greater depths. If a diver is working at depths of 33 feet or less, he will need only 30 to 40 pounds per square inch for optimum operation of his regulator.

Most Hookah compressors have a built in "pressure relief valve" which prevents excessive pressure from building up in the compressor head when the diver is only making a small "demand" on the compressor. This valve is usually preset at the factory at approximately 50 p.s.i., which will give the average diver at shallow depths enough air to operate his regulator while leaving enough pressure left over to allow for increased exer-

tion. If a diver is breathing at a normal rate (light exertion), the pressure relief valve will occasionally "pop off" and shoot out a burst of air. This is normal, as it prevents excess buildup of pressure in the compressor head. If a diver is breathing heavily and is under physical exertion, he will be demanding all of the volume and pressure that the compressor can deliver. In this case, the pressure relief valve will rarely, if ever discharge excess pressure or "pop off."

The type of Hookah compressor that is required for a given diving operation is dependent upon the extent of underwater physical exertion, the depth, and the number of divers that are connected to the system. A single diver under light exertion at shallow depths will require a relatively small air output that is measured in "cubic feet per minute," or "CFM". The same diver under heavy exertion will require additional air at a slightly higher pressure and volume.

If more than one diver is connected to an air system, or if diving at greater than normal depths, more air volume at higher pressures may be required.



Air Reserve Tank Model RT-1

THE AIR RESERVE TANK

The next major component in the Hookah air system is the reserve tank. This very important piece of equipment performs four vital functions:

The reserve tank operates as an air "reservoir," that supplies a constant volume of air at all times. If, you are diving under heavy exertion and demanding a greater amount of air, the large volume of air in the reserve tank will supply the reserve air required. If you were breathing directly from compressor itself, your rate of inhalation might actually surpass the air volume provided by the compressor, and you would not get a sufficient amount of air.

The reserve tank functions as a cooling and condensation vessel. Few divers realize it, but the air emerging from a Hookah compressor is quite hot, and can actually reach temperatures as high as 190 degrees.

As the air enters the the reserve tank, it will expand and cool. This expansion process will also condense most of the water contained in the compressed air. Hookah compressors, because of their small size, do not have the capability to remove the moisture from the air and hence, they deliver air with an appreciable moisture content. The expansion process in the reserve tank allows the water to condense, ensuring that the diver breaths less moisture in the air.

The reserve tank also suppresses surges from the compressor or any temporary decrease in running speed. Often a the compressor's engine will run uneven due to moisture in the gasoline. The reserve tank can compensate for this by delivering an even flow of air.

And finally, the most important function of all. The reserve tank will contain enough pressurized air to give the diver a couple of minutes breathing time, should his compressor, or engine failure run out of fuel. Equipment breakdown is not a pleasant thing to consider while working underwater, but is always a possibility. In the event of an engine failure without a reserve tank in the system, a diver could experience an immediate loss of air that could lead to desperation and panic. Any experienced diver will tell you, that panic is the leading cause of drowning incidents.

THE AIR HOSE

The next component in the Hookah air system is the air hose. Hookah air hose is made of a special vinyl plastic construction, is resistant to the effects of oil, gasoline and sunlight that exists in the environment.

Conventional rubber hose should never be used for diving, because it will gradually deteriorate and become toxic. Hookah hose commonly has an inside diameter of 3/8ths. of an inch. It is constructed of an inner liner of food grade vinyl wrapped with a nylon webbing reinforcement and covered with a heavy duty PVC abrasion resistant wall. Hookah hose is

designed to prevent kinking and collapsing that could prevent the flow of air being shut off

A quality Hookah hose will be colored a bright yellow or orange, for a high degree of visibility. It will also float, so that any excess hose not actually being used will float on the surface, completely away from the diver, reducing the possibility of entanglements on the bottom. For example, if you are diving in ten feet of water but are using a thirty foot length of air hose, the excess twenty feet will float on the surface, completely away from you.

A quality Hookah air will not impart any "flavoring" to the air, and should meet "FDA and OSHA" requirements.

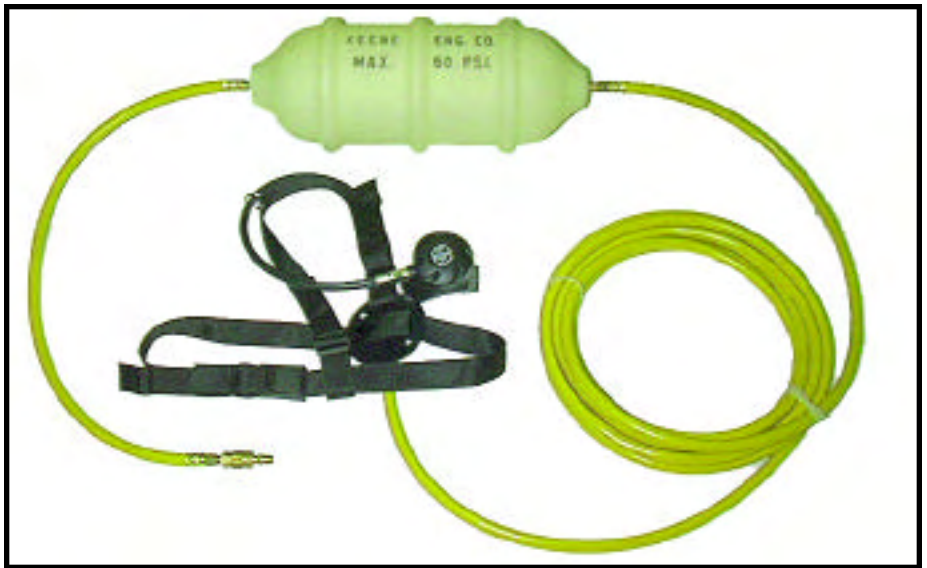

Typical air system for one diver, including air hose, reserve tank, regulator, harness, and connector hose to compressor



Typical Hookah Air Regulator and Harness

THE REGULATOR

The regulator is an oral respiration device that is worn in the divers mouth. The regulator regulates the amount of air that is received by the diver each time he inhales. Because the divers nose is covered by his face mask, air must be inhaled through the divers mouth .

There are two types of diving regulators, those designed for SCUBA use and those designed for Hookah applications. A SCUBA regulator is designed for use with SCUBA a air tank, and delivers maximum efficiency when operated at a pressure exceeding 100 p.s.i. They require a "first stage" valve assembly, attached to the SCUBA tank. The function of the first stage is to reduce the extremely high pressure of the air in the SCUBA tank from approximately 2,250 p.s.i. to approximately 180 p.s.i. This pressure then goes to the

"second stage," which is the part that is worn in the diver's mouth. The second stage of a SCUBA regulator has a spring loaded "downstream" valve which delivers the correct amount of air to the diver when driven by an air pressure ranging from 100 to 250 p.s.i.

A prospective Hookah diver must realize that SCUBA regulators CAN-NOT be used for Hookah applications without special modifications. A typical Hookah compressor operates in an average pressure range of 30 to 50 p.s.i., which is not enough pressure to drive the spring loaded downstream valve of a SCUBA regulator. A diver who already owns a SCUBA regulator, but who wishes to use it for Hookah applications, must take his regulator to a competent dive shop or repair station and get the regulator converted over for low pressure use; he should not attempt to do it himself. The conversion can be made by installing a set of low tension springs which will give maximum efficiency when operated at low Hookah pressures. A dive shop or repair station will also have the necessary test gauges, etc., to make certain the adaptation has been effective.

A Hookah regulator is entirely different from a SCUBA regulator. It consists of a "second stage" only, which is fed directly from the output of the reserve tank via the air hose. There are no valve assemblies of the type that are used with SCUBA tanks. Hookah regulators employ a "tilt," or

"pin" valve, which delivers a full air flow to the diver at a pressure as low as 30 p.s.i. This type of regulator is specifically designed for use with low pressure Hookah compressors. Hookah regulators, as are all modern regulators, are of the single hose, "demand" type. A "demand" regulator works on a relatively low volume of air, since it only has to deliver air as the diver breathes, or "demands" it..



THE HARNESS

A regulator should not be used for Hookah diving unless it is in conjunction with a "chest harness." The harness serves two principle functions:

1. It keeps the air hose from getting in the diver's way when he is working underwater. The harness has a "back plate" which is automatically positioned over the center of the diver's back when the harness is Since the air hose terminates at the diver's back, it prevents potential entanglements around the diver's body.

2. The regulator intake hose that attaches to the check valve prevents any pulling motion from the regulator while working underwater. For example; if a diver were moving around underwater and inadvertently came to the end of the air hose, the harness would absorb the shock and the regulator and would not be jerked from the diver's mouth.

INCIDENTAL ACCESSORIES, HOSES, HINTS, PRECAUTIONS:

One accessory hose item you will need is a short length of hose for routing the air output from the compressor to the input of the reserve tank. The type of hose that is needed depends upon the compressor you are using. Diaphragm models that operate in the 30 to 50 p.s.i. range use a simple hose connector that is made of hookah air hose. The high pressure, high volume piston compressors that are capable of delivering pressure of 100 p.s.i., require a connector made of special certified "heat resistant steam" hose, due to the fact that these models discharge air at higher temperatures.

When setting up a Hookah air system, you will frequently need an array of metal fittings. For use around water, you should use stainless steel or brass fittings only. This is especially important when diving in salt water.

Fittings made of ferrous metal will rust or corrode when used in, or near a water environment.

If your Hookah compressor is powered by a gasoline engine, make every effort to ensure that the engine exhaust (which contains deadly carbon monoxide gas), is always placed DOWNWIND from the compressor. This will help prevent exhaust from being accidentally pulled into the compressor's air inlet. Always use a "snorkel" extension on any compressor that can elevate the intake of the air supply away from engine exhaust contaminants.

Never use a gasoline powered compressor in confined areas, such as underneath piers, in close, narrow grottos, etc. This will prevent the exhaust gases from dissipating into the atmosphere safely. Also, never dive in an area where there is little ventilation or air movement. Take

special precautions when diving in areas where the air is extremely still, as dead air spaces, or poor ventilation can cause exhaust gases to linger in the immediate area of the engine and compressor unit.

Always install a long extension on the intake of your compressor to avoid the possibility of contamination of Carbon Monoxide Gas from the engine exhaust system. The air intake of a compressor must tower over the engine exhaust at a sufficient height or distance to avoid intake of engine exhaust gas. If this gas is inhaled even in small quantities for short periods, it can cause severe headaches and possibly result in sickness. In larger quantities it can kill you, so please be careful!

If you are using Hookah equipment around salt water, be sure to rinse off all your components with freshwater afterwards. This includes your regulator, diving mask, harness, metal fittings, and air hose (flush it out on the inside as well as outside). A salt water environment will quickly corrode aluminum parts such as: Hookah compressors and gasoline engines. It is advisable to keep all metal components freshly painted and cleaned to avoid excess corrosion.

If you are using a gasoline powered compressor always shut of the engine before attempting to refuel. Do not attempt to refill the engine's gas tank while the engine is still running, as this will increase the possibility of spilling gasoline onto a hot engine, which could result in a potential fire or cause an explosion.

A diver should always surface and shut off the engine first prior to refueling and allow time for the engine to cool down. Always use a funnel for refilling the gas tank, or a special spillproof gas container to prevent spillage.

Every Hookah diver should understand the basic rudiments of engine and compressor maintenance, and should always keep his equipment in top condition. If you take proper care of your equipment, it will give you many years of trouble free service. Knowing how to work on your own equipment will also come in handy, should you experience any mechanical failure on a diving trip. It is a good idea to carry

along some spare parts for your air compressor, and the necessary tools to make repairs.

All of the basic "rules of the deep" that apply to SCUBA diving also apply to Hookah diving as well.

UNDER NO CIRCUMSTANCES SHOULD YOU DIVE ALONE!

Always Hookah dive with a partner who owns his own regulator, harness, and air hose.

Make sure that his or her equipment as well as yours is attached to the air system at all times. If you were to experience underwater problems, your "diving partner" should be available to come to your immediate assistance.

Even though no formal instruction is required to use Hookah equipment, we strongly recommend that all divers should take a "CERTIFIED SCUBA" course at your local county or diving supply store.

You should also read books on the subject of underwater diving safety and study them thoroughly. This will further familiarize you with the "rules of the deep."

New 12volt system HAS



WARNING CARBON MONOXIDE GAS

If you're considering diving with a "Hookah Compressor", It is most important that you become aware of Potential Danger associated with exhaust emissions. We place a caution label on the engine, warning of dangerous engine fumes and also illustrate further warning in " Introduction to Hookah Diving" and Safety in Gold Dredging that is issued with the purchase of all diving equipment.

WHAT IS CARBON MONOXIDE GAS?

Carbon Monoxide is an invisible odorless gas which gives no warning of its presence. It is the product of the incomplete burning of any material such as ; Oil Gasoline, Wood, Coal, etc. that contains carbon.

WHAT IS THE EFFECT OF CARBON MONOXIDE EXPOSURE?

Carbon Monoxide deprives the blood of its ability to carry oxygen throughout the body. When Carbon Monoxide is inhaled , it chemically combines with hemoglobin, the oxygen carrier in the blood. Even if there is plenty of oxygen in the air, hemoglobin combines much more readily with Carbon Monoxide than with oxygen. As the oxygen level of the blood is reduced, the heart must pump faster in an effort to supply sufficient amounts of oxygen to the brain and other parts of the body. When the brain does not receive enough oxygen, symptoms of headache, dizziness and mental confusion occur. Further exposure to the gas causes lack of coordination, weakness and nausea. The final effect of excessive exposure are convulsions, coma and death.

Needless to say, we cannot emphasize strongly enough that caution must be exercised. Never dive alone, never dive in an enclosed area, or in an area where good ventilation is not eminent such as; under piers, narrow grottos, under heavily overgrown brush or trees or in any area where a good breeze does not occur. Always make an effort to position your air unit to allow the prevailing breeze to carry any exhaust emissions away from the air intake of the compressor.

Remember, Carbon Monoxide is the product of incomplete burning of gasoline and oil, so it most important to keep your unit properly running and clean. Never allow gasoline to overfill or spill anywhere near engine and compressor.

THE SAFETY AIR SNORKEL DOES NOT ELIMINATE CARBON MONOXIDE GAS, IT ONLY AIDS IN THE REDUCTION OF FUMES. ALL THE SAFETY CAUTIONS MUST BE OBSERVED !

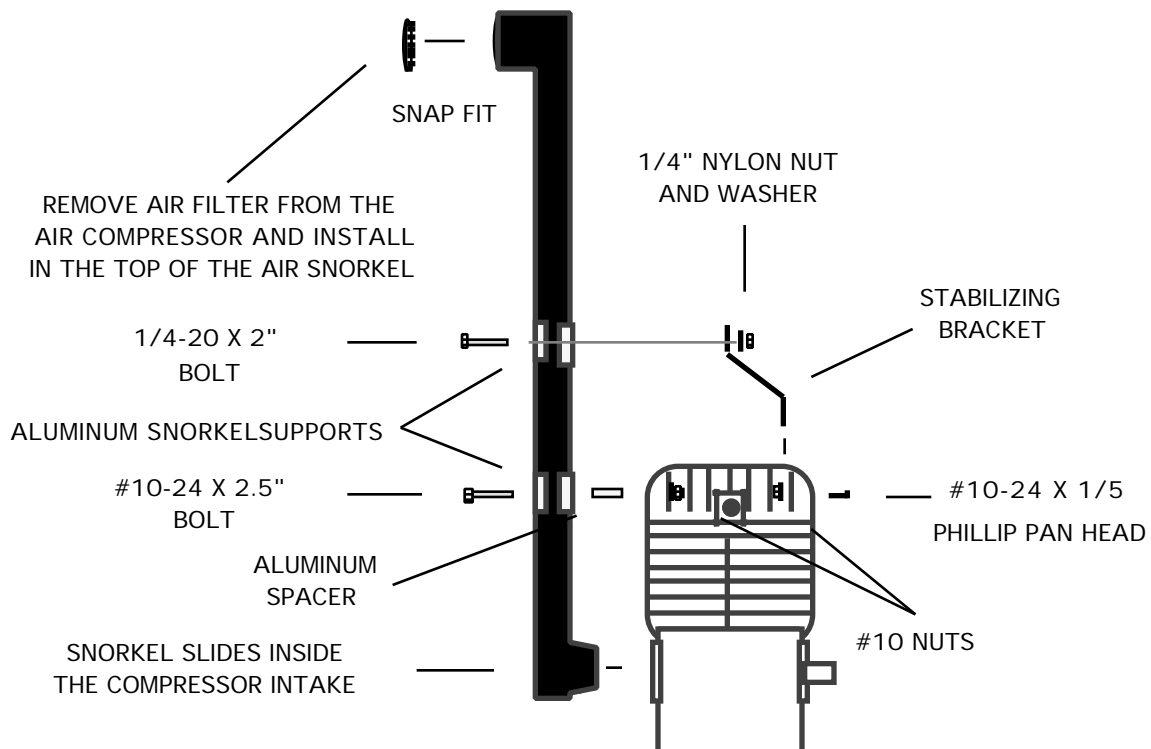

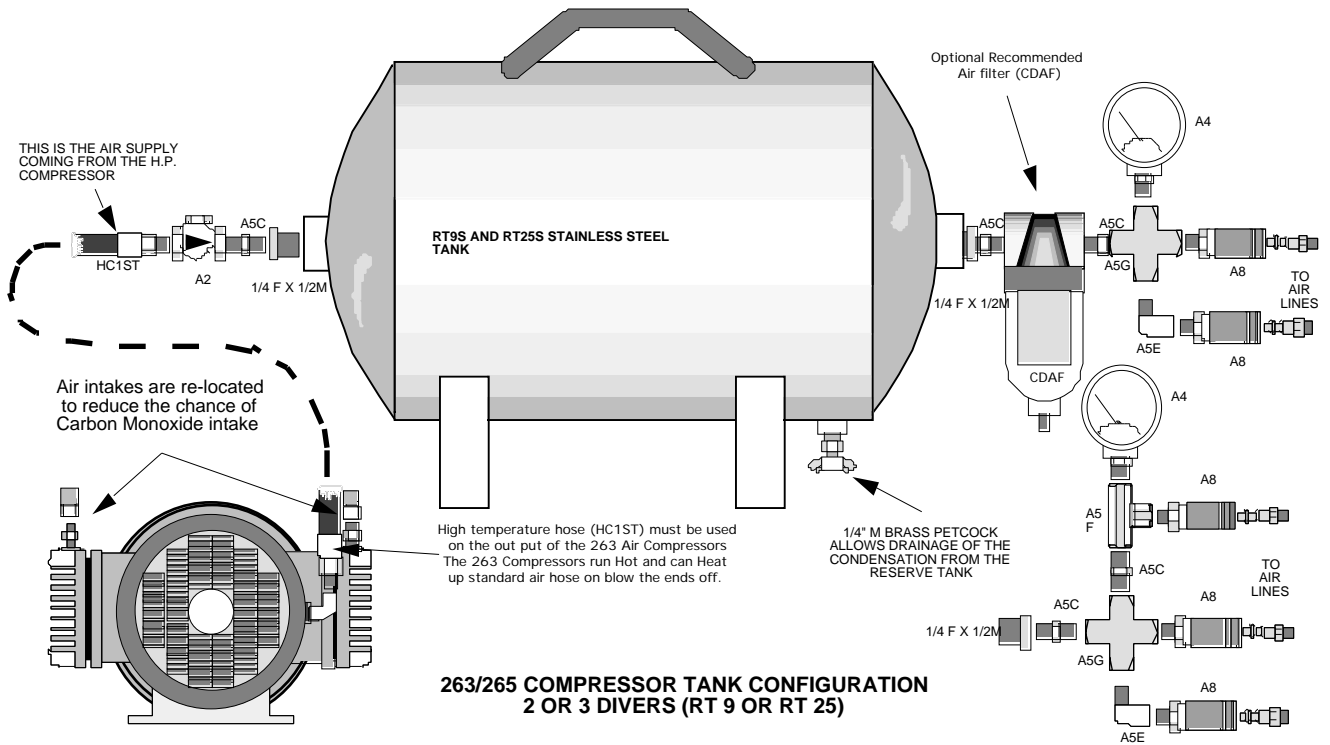

263G & 263GH

Remote air intakes reduce the chance of Carbon Monoxide Poisoning

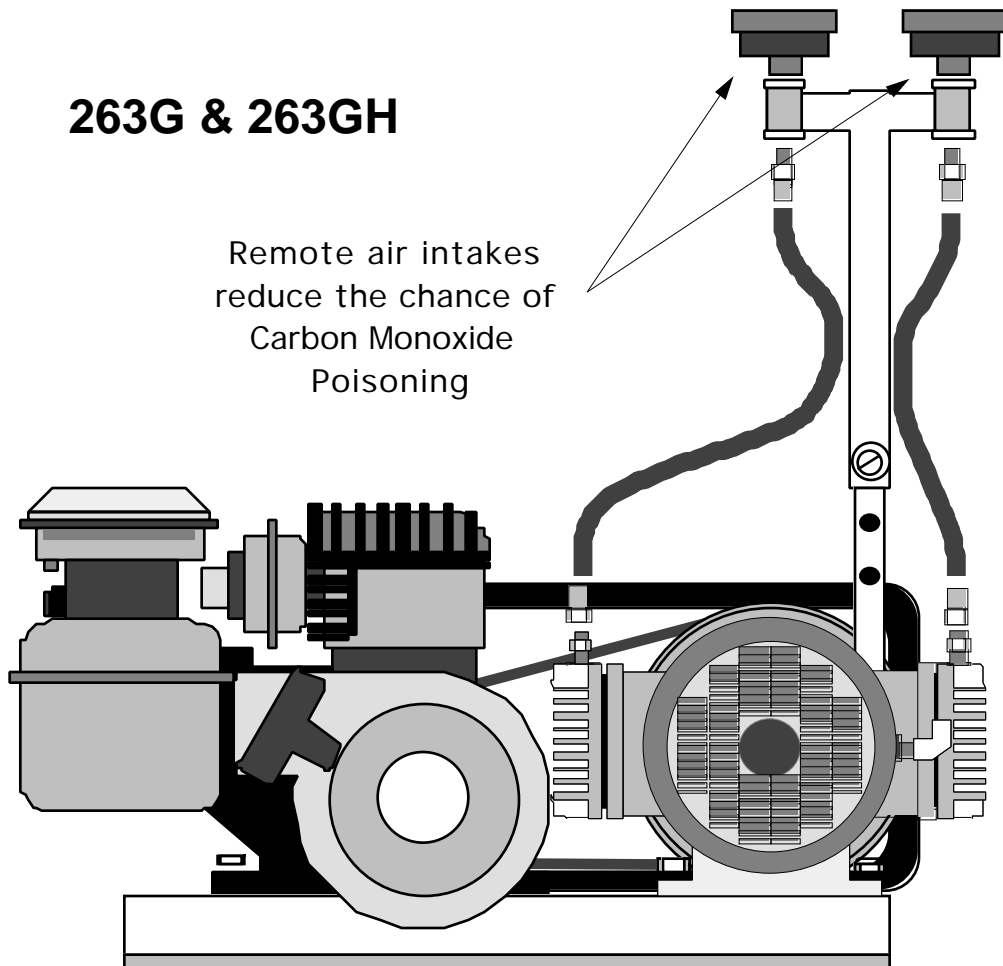

Harness Instructions

The regulator hose slides through the D Ring and attaches to the check valve on the back of the harness



The regulator hose slides through the D Ring and attaches to the check valve on back plate.

